



RADIK[®] KLASIK



Steel panel radiators





KEY FEATURES AND BENEFITS

- 10 year warranty •
 - made to last •
 - high quality finish •
- pressure tested to 13 bar •
 - low water content •
- excellent packaging on all corners and edges •
- ISO 9001:2008 guarantee of quality of products and services •

General information

The radiators are made in one of the most modern factories in Europe in an area of 30 000 sq metre, and are currently delivered to 35 countries worldwide.

The satisfaction of the customer is our main purpose and that aim influences the goals and plans for KORADO. An excellent combination of panel and towel radiators provides a total heating package to the UK market.

KORADO KLASIK panel radiator range is available in types 11, 21, 22. Stock sizes include five heights - 300, 400, 500, 600, 900 - and a wide range of lengths from 400 mm up to 3000 mm.

Basic equipment

All KORADO KLASIK radiators have two upper and lower hangers welded on the back. Radiators 1800 mm long and longer have three pairs.

All radiators have top grills and end panels factory fitted. Also radiators are supplied with an air vent and blanking plug, all tappings are 1/2" BSP internal thread.

Guarantees and Quality



Korado products are manufactured to the highest standards, using only the best materials with quality control at all levels of production under the quality standard ISO 9001: 2000. Heat outputs have been tested and approved to EN 442.

The manufacturer guarantees that the product is leak proof and guarantees stated heat output of RADIK steel panel radiators connected to the hot-water systems for 10 years from the date of sale. The manufacturer accepts no responsibility for deformation or damage of the radiators caused during their transport, handling, or storage. The guarantee does not apply to mechanical or other damages caused by unqualified installation of the radiators.

Packaging

KORADO packaging is very strong and gives the radiator total protection. It consists of corrugated cardboard, and poly-ethylene shrink wrap. A total protection of the corners is guaranteed by reinforced plastic covers which are placed on the radiator before the shrink wrap is applied.

HEAT OUTPUT IN WATTS CERTIFIED TO EN 442 (DELTA T 50)

| 20 °C | | Type 11 Width: 63 mm | | | | | Type 21 Width: 66 mm | | | | | Type 22 Width: 100 mm | | | | |
|---------------|-----------------|---|-----------|-----------|-----------|-----------|--|-----------|-----------|-----------|-----------|---|-----------|-----------|-----------|-----------|
| | |  | | | | |  | | | | |  | | | | |
| Height H [mm] | | 300 (12") | 400 (16") | 500 (20") | 600 (24") | 900 (35") | 300 (12") | 400 (16") | 500 (20") | 600 (24") | 900 (35") | 300 (12") | 400 (16") | 500 (20") | 600 (24") | 900 (35") |
| Length L [mm] | Length L [inch] | (W) Btu/h | (W) Btu/h | (W) Btu/h | (W) Btu/h | (W) Btu/h | (W) Btu/h | (W) Btu/h | (W) Btu/h | (W) Btu/h | (W) Btu/h | (W) Btu/h | (W) Btu/h | (W) Btu/h | (W) Btu/h | (W) Btu/h |
| 400 | 16 | | | 343 | 401 | 558 | | | 447 | 515 | 702 | | 486 | 581 | 672 | 925 |
| | | | | 1171 | 1368 | 1903 | | | 1524 | 1758 | 2394 | | 1660 | 1982 | 2291 | 3157 |
| 500 | 20 | 275 | 354 | 429 | 501 | 697 | | | 559 | 644 | 877 | 483 | 608 | 726 | 840 | 1157 |
| | | 937 | 1208 | 1464 | 1709 | 2378 | | | 1906 | 2197 | 2992 | 1648 | 2074 | 2477 | 2864 | 3946 |
| 600 | 24 | 329 | 425 | 515 | 601 | 836 | | | 670 | 773 | 1052 | 580 | 730 | 871 | 1007 | 1388 |
| | | 1124 | 1449 | 1756 | 2051 | 2854 | | | 2287 | 2637 | 3591 | 1978 | 2489 | 2973 | 3437 | 4735 |
| 700 | 28 | 384 | 496 | 601 | 701 | 976 | | | 782 | 902 | 1228 | 676 | 851 | 1016 | 1175 | 1619 |
| | | 1311 | 1691 | 2079 | 2393 | 3329 | | | 2668 | 3076 | 4189 | 2307 | 2904 | 3468 | 4010 | 5524 |
| 800 | 31 | 439 | 566 | 686 | 802 | 1115 | 596 | 750 | 894 | 1030 | 1403 | 773 | 973 | 1162 | 1343 | 1850 |
| | | 1499 | 1933 | 2342 | 2735 | 3805 | 2034 | 2558 | 3049 | 3516 | 4788 | 2637 | 3319 | 3963 | 4583 | 6314 |
| 900 | 35 | 494 | 637 | 772 | 902 | 1255 | 671 | 843 | 1005 | 1159 | 1579 | 869 | 1094 | 1307 | 1511 | 2082 |
| | | 1686 | 2174 | 2635 | 3077 | 4281 | 2288 | 2877 | 3430 | 3955 | 5386 | 2966 | 3734 | 4459 | 5156 | 7103 |
| 1000 | 39 | 549 | 708 | 858 | 1002 | 1394 | 745 | 937 | 1117 | 1288 | 1754 | 966 | 1216 | 1452 | 1679 | 2313 |
| | | 1873 | 2416 | 2927 | 3419 | 4756 | 2542 | 3197 | 3811 | 4395 | 5985 | 3296 | 4149 | 4954 | 5729 | 7892 |
| 1100 | 43 | 604 | 779 | 944 | 1102 | 1533 | 820 | 1031 | 1229 | 1417 | 1929 | 1063 | 1338 | 1597 | 1847 | 2544 |
| | | 2061 | 2657 | 3220 | 3761 | 5232 | 2796 | 3517 | 4192 | 4834 | 6583 | 3626 | 4564 | 5450 | 6302 | 8681 |
| 1200 | 47 | 659 | 850 | 1030 | 1202 | 1673 | 894 | 1124 | 1340 | 1546 | 2105 | 1159 | 1459 | 1742 | 2015 | 2776 |
| | | 2248 | 2899 | 3513 | 4103 | 5708 | 3050 | 3836 | 4573 | 5274 | 7182 | 3955 | 4979 | 5945 | 6874 | 9470 |
| 1400 | 55 | 769 | 991 | 1201 | 1403 | 1952 | 1043 | 1312 | 1564 | 1803 | 2456 | 1352 | 1702 | 2033 | 2351 | 3238 |
| | | 2622 | 3382 | 4098 | 4786 | 6659 | 3559 | 4476 | 5336 | 6153 | 8379 | 4614 | 5809 | 6936 | 8020 | 11049 |
| 1600 | 63 | 878 | 1133 | 1373 | 1603 | 2230 | 1192 | 1499 | 1787 | 2061 | 2806 | 1546 | 1946 | 2323 | 2686 | 3701 |
| | | 2997 | 3865 | 4684 | 5470 | 7610 | 4067 | 5115 | 6098 | 7031 | 9575 | 5274 | 6638 | 7927 | 9166 | 12627 |
| 1800 | 71 | 988 | 1274 | 1544 | 1804 | 2529 | 1341 | 1687 | 2011 | 2318 | 3148 | 1739 | 2189 | 2614 | 3022 | 4148 |
| | | 3372 | 4348 | 5269 | 6154 | 8514 | 4575 | 5755 | 6860 | 7910 | 10648 | 5933 | 7468 | 8918 | 10312 | 14011 |
| 2000 | 79 | 1098 | 1416 | 1716 | 2004 | 2784 | 1490 | 1874 | 2234 | 2576 | 3516 | 1932 | 2432 | 2904 | 3358 | 4548 |
| | | 3746 | 4831 | 5855 | 6838 | 9414 | 5084 | 6394 | 7622 | 8789 | 11816 | 6592 | 8298 | 9908 | 11457 | 15546 |
| 2300 | 91 | | | 1973 | 2305 | 3141 | | | | | | 2222 | 2797 | 3340 | 3862 | 5208 |
| | | | | 6733 | 7863 | 10714 | | | | | | 7581 | 9543 | 11395 | 13176 | 17741 |
| 2600 | 102 | | | 2231 | 2605 | 3554 | | | | | | 2512 | 3162 | 3775 | 4365 | 5861 |
| | | | | 7611 | 8889 | 12014 | | | | | | 8570 | 10787 | 12881 | 14895 | 20046 |
| 3000 | 118 | | | 2574 | 3006 | 4065 | | | | | | 2898 | 3648 | 4356 | 5037 | 6768 |
| | | | | 8782 | 10256 | 13815 | | | | | | 9888 | 12447 | 14863 | 17186 | 23111 |

| | | | | | | | | | | | | | | | |
|---|--------------------------------|--------|------------|--------|-------------|--------------------------------|------------|--------|-------------|--------|--------------------------------|--------|-------------|--------|--------|
| Standard heat output [W/m] | 549 | 708 | 858 | 1002 | 1394 | 745 | 937 | 1117 | 1288 | 1754 | 966 | 1216 | 1452 | 1679 | 2313 |
| Temp. exponent n [-] | 1,3156 | 1,3140 | 1,3123 | 1,3107 | 1,3206 | 1,3197 | 1,3238 | 1,3278 | 1,3319 | 1,3578 | 1,3297 | 1,3316 | 1,3334 | 1,3353 | 1,3574 |
| K _r | c ₀ | | 0,01407200 | | 1,34220000 | | 0,03399300 | | 1,35050000 | | 0,05120200 | | 1,34380000 | | |
| b | c ₁ | | 0,94200000 | | -0,00004407 | | 0,83090000 | | -0,00002395 | | 0,80550000 | | -0,00000514 | | |
| Radiator weight [kg/m] | 10,42 | 14,15 | 17,87 | 21,60 | 32,80 | 15,60 | 20,57 | 25,53 | 30,50 | 47,00 | 18,40 | 24,37 | 30,33 | 36,30 | 56,30 |
| Water volume [l/m] | 1,9 | 2,3 | 2,7 | 3,1 | 4,3 | 3,7 | 4,4 | 5,1 | 5,8 | 8,3 | 3,7 | 4,4 | 5,1 | 5,8 | 8,4 |
| Flow coefficient A _r [m ²] | 6,5 x 10 ⁻⁵ (DN 15) | | | | | 1,0 x 10 ⁻⁴ (DN 15) | | | | | 1,0 x 10 ⁻⁴ (DN 15) | | | | |
| Resistance coefficient ξ _r [-] | 19,0 (DN 15) | | | | | 8,5 (DN 15) | | | | | 8,5 (DN 15) | | | | |

Characteristic equation: $\Phi = K_r \cdot H^b \cdot \Delta T^{(c_0 + c_1 \cdot H)}$

Conversion information

The outputs quoted in this publication are based on a Delta T 50. To calculate other operating conditions, the following example should be applied:

EXAMPLE:

Add flow water temperature (75 °C) and the return water temperature (65 °C) together (140 °C), divide by two (70 °C) and then subtract the room temperature (20 °C).

This will give you a Delta T factor 50.



RADIK® KLASIK

Finish

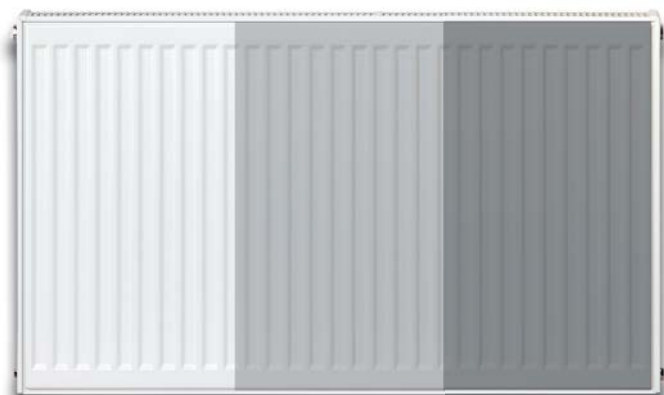

3. **2.** **1.**

- 1.** Degreasing and phosphating
- 2.** Cataphoresis paint
- 3.** Epoxy-polyester powder

Every radiator undergoes a multi stage pre-treatment process which includes degreasing, phosphating, and rinsing in three stages. Then KTL paint is applied which is vital for the long life span of the radiator. The final touch is done by a stoved epoxy-polyester powder coat in white.

The surface finishing of the radiators is done with maximum care.

The finish guarantees:
 Long - term corrosion resistance
 Mechanical durability

Table of sizes

| Type | 11 | 21 | 22 |
|-----------|----------|----------|-----------|
| X1 | 69 / 48 | 77 / 56 | 94 / 73 |
| X2 | 101 / 80 | 110 / 89 | 144 / 123 |

Producer

KORADO, a. s.
 Bří Hubálků 869, 560 02 Česká Třebová
 Czech Republic
 Tel.: +420 465 506 422
 Fax: +420 465 533 126
 e-mail: info@korado.cz, http://www.korado.com

UK Sales

STEVE RUGMAN
 Tel: 0044 1453 844 275
 Mobile: 0044 7872 304 285
 E-mail: steve.rugman@korado.co.uk

All rights to carry out changes due to technical development are reserved.
 07/10.601.2 EN

Technical Data

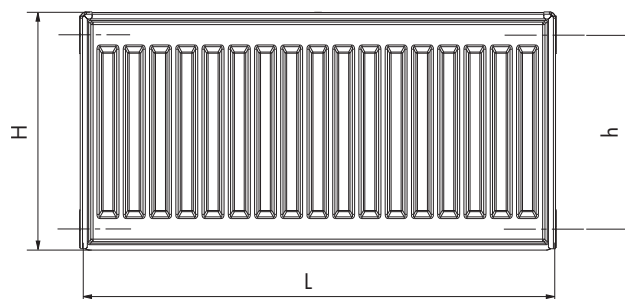

| | |
|--|---|
| Height H | 300, 400, 500, 600, 900 mm |
| Length L | 400, 500, 600, 700, 800, 900, 1000, 1100, 1200, 1400, 1600, 1800, 2000, 2300, 2600, 3000 mm |
| Connecting pitch | $h = H - 54$ mm |
| Connecting thread | 4 x G1/2 inside |
| Highest allowed working pressure | 10 bar |
| Highest allowed working temperature | 110 °C |
| Radiator connection | left or right side |

Position of radiator

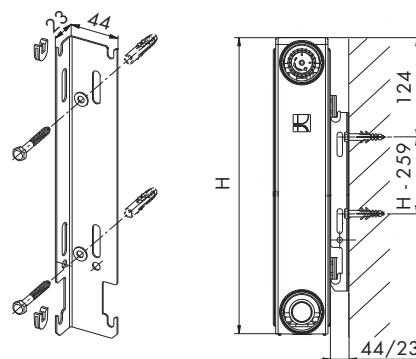
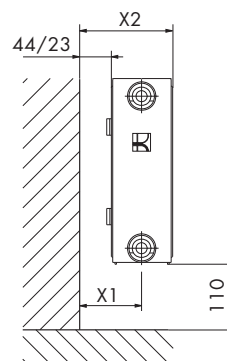

Distributor